

General Description

The SE1482 is a monolithic synchronous buck regulator. The device integrates 95 mΩ MOSFETS that provide 2A continuous load current over a wide operating input voltage of 4.5V to 27V. Current mode control provides fast transient response and cycle-by-cycle current limit. An adjustable soft-start prevents inrush current at turn on.

Features

- 2A Output Current
- Wide 4.5V to 27V Operating Input Range
- Output Adjustable from 0.925V to 0.8Vin
- Up to 96% Efficiency
- Programmable Soft-Start
- Stable with Low ESR Ceramic Output Capacitors
- Fixed 340KHZ Frequency
- Cycle-by-Cycle Over Current Protection
- Short Circuit Protection
- Input Under Voltage Lockout
- Package : SOP-8/PSOP-8

Pin Configuration

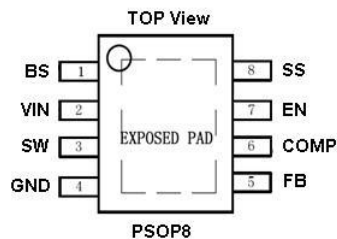
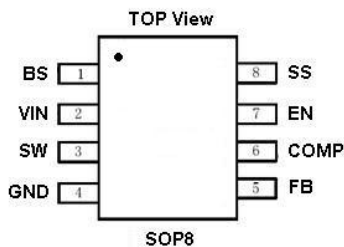

Applications

- Distributed Power Systems
- Green Electronics/ Appliances
- Notebook Computers
- Networking Systems
- FPGA, DSP, ASIC Power Supplies

Typical Application

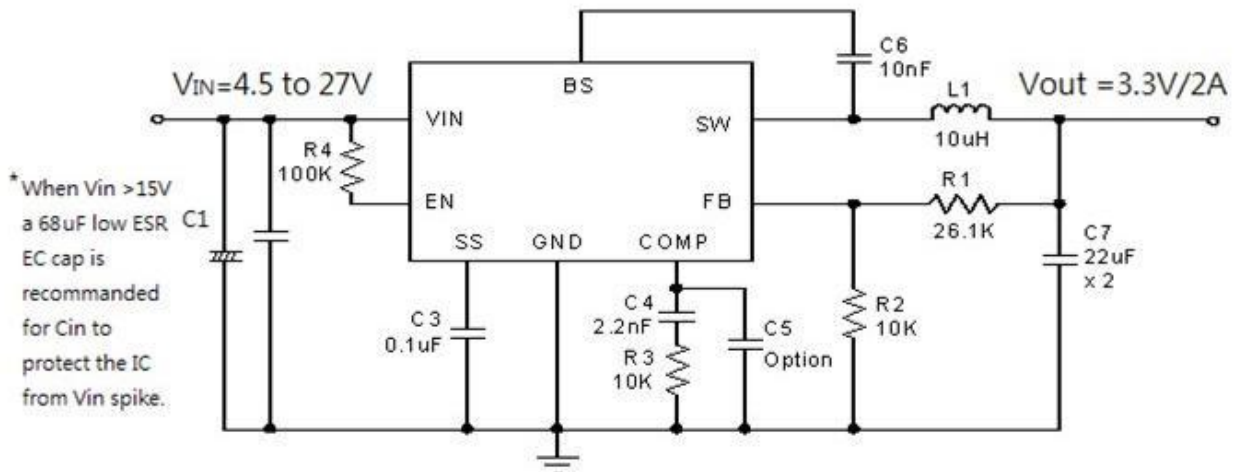



Functional Block Diagram

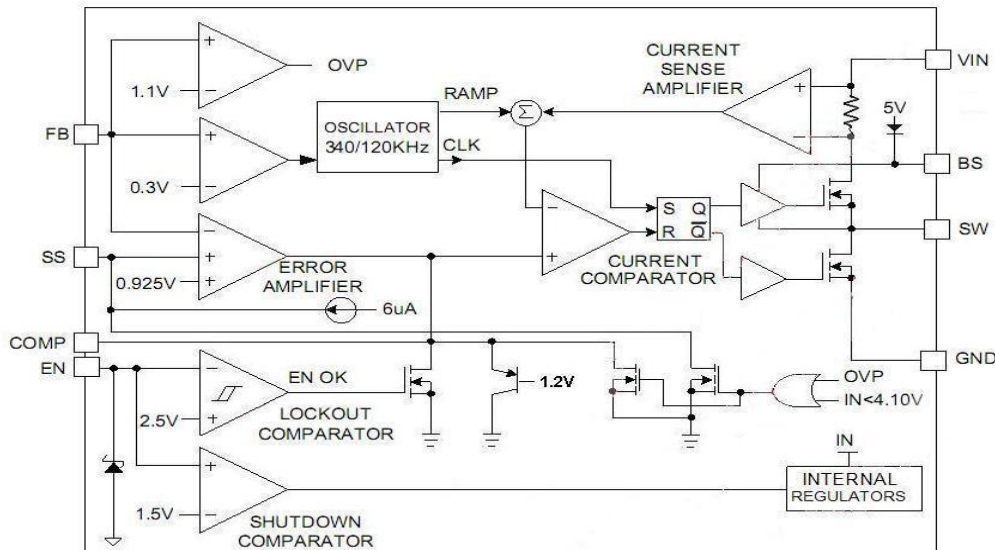

Ordering Information

Part Number	Marking Information	Package	Remarks
SE1482-HF	SE1482	SOP8	YYWW means Production batch XX=HF: Halogen Free.
	YYWW-HF	PSOP8	

Pin Descriptions

Pin Num	Pin	Descriptions
1	BS	Bootstrap. This pin acts as the positive rail for the high-side switch's gate driver. Connect a 0.01uF capacitor between BS and SW.
2	Vin	Input Supply. Bypass this pin to GND with a low ESR capacitor. See Input Capacitor in the Application Information section.
3	SW	Switch Output. Connect this pin to the switching end of the inductor.
4	GND	Ground.
5	FB	Feedback Input. The voltage at this pin is regulated to 0.925V. Connect to the resistor divider between output and ground to set output voltage.
6	COMP	Compensation Pin. See Stability Compensation in the Application Information section.
7	EN	Enable Input. When higher than 2.7V, this pin turns the IC on. When lower than 1.1V, this pin turns the IC off. Output voltage is discharged when the IC is off. This pin should not be left open. Recommend to put a 100KΩ pull up resistor to Vin for start up.
8	SS	Soft-Start Control Input. SS controls the soft-start period. Connect a capacitor from SS to GND to set the soft-start period. A 0.1uF capacitor sets the soft-start period to 15ms. To disable the soft-start feature, leave SS unconnected.



Absolute Maximum Rating

Parameter	Maximum	Units
Input Supply Voltage	-0.3 to 30	V
SW Voltage	-0.3 to $V_{IN} + 0.3$	V
BS Voltage	$V_{SW} - 0.3$ to $V_{SW} + 6$	V
EN, FB, COMP Voltage	-0.3 to 5	V
Continuous SW Current	Internally limited	A
Junction to Ambient Thermal Resistance (θ_{JA})	87	°C/W
PSOP-8 Power Dissipation	Internal limit	W
Maximum Junction Temperature	150	°C
Storage Temperature Range	-65 to 150	°C

Note: Exceeding these limits may damage the device. Even the duration of exceeding is very short. Exposure to absolute maximum rating conditions for long periods may affect device reliability.

Recommended Operating Conditions

Parameter	Symbol	Value	Units
Supply Input Voltage	V_{IN}	4.5 to +27	V
Operating Junction Temperature	T_J	-20 to +125	°C

Electrical Characteristics

$V_{IN} = 12V$; $T_J = 25^\circ C$; unless otherwise specified

Parameter	Symbol	Conditions	Min	Typ	Max	Unit
Feedback Voltage	V_{FB}	$4.5V \leq V_{IN} \leq 27V$	0.9	0.925	0.95	V
Feedback Overvoltage Threshold				1.1		V
High-Side Switch-On Resistance*				95		mΩ
Low-Side Switch-On Resistance*				95		mΩ
High-Side Switch Leakage		$V_{EN} = V_{SW} = 0V$,		10	uA
Upper Switch Current Limit*		Min Duty Cycle	2.7	3.5		A
COMP to Current Limit Trans conductance	G_{COMP}			3.3		A/V
Error Amplifier Trans conductance	G_{EA}	$\Delta I_{COMP} = \pm 10uA$		920		uA/V
Error Amplifier DC Gain*A	V_{EA}			480		V/V
Switching Frequency	f_{SW}			340		KHz
Short Circuit Switching Frequency		$V_{FB} = 0V$		120		KHz
Maximum Duty Cycle	D_{MAX}	$V_{FB} = 0.8V$		92		%
Minimum On Time*				220		nS
EN Shutdown Threshold Voltage		V_{EN} Rising	1.1	1.4	2	V
EN Shutdown Threshold Voltage Hysteresis				180		mV



EN Lockout Threshold Voltage			2.2	2.5	2.7	V
EN Lockout Hysteresis				130		mV
Supply Current in Shutdown		$V_{EN} = 0V$		0.3	3	μA
IC Supply Current in Operation		$V_{EN} = 3V,$ $V_{FB} = 1.0V$		1.3	1.5	mA
Input UVLO Threshold Rising	UVLO	V_{EN} Rising	3.8	4.05	4.4	V
Input UVLO Threshold Hysteresis				100		mV
Soft-start Current		$V_{SS} = 0V$		6		μA
Soft-start Period		$C_{SS} = 0.1\mu F$		15		mS
Thermal Shutdown Temperature*		Hysteresis $= 25^{\circ}C$		160		$^{\circ}C$

Note: * Guaranteed by design, not tested

Typical Application

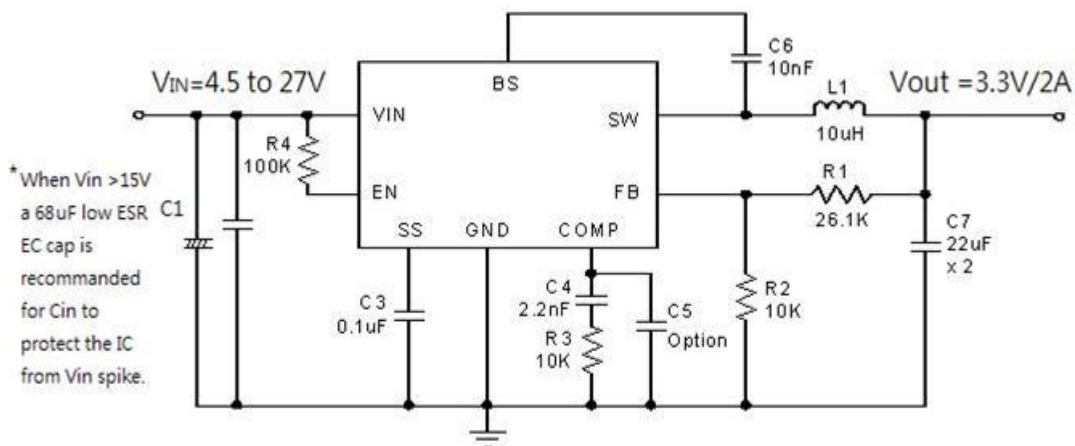

SE1482 Circuit, 3.3V/2A output

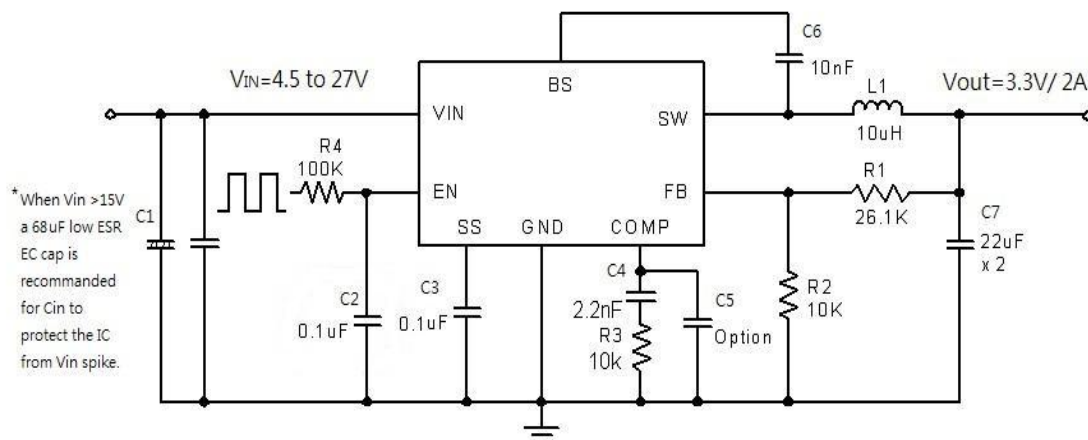

SE1482 Circuit, 3.3V/2A output with EN function

Note: **C2** is required for separate EN signal.

Applications

Output Voltage Setting

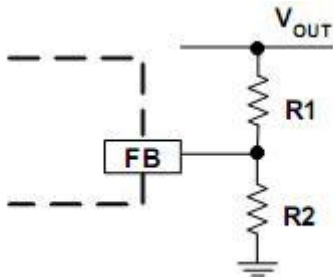

Figure1. Output Voltage Setting

Figure 1 shows the connections for setting the output voltage. Select the proper ratio of the two feedback resistors R1 and R2 based on the output voltage. Typically, use $R2 \approx 10K\Omega$ and determine R1 from the following equation:

$$R1 = R2 \left(\frac{V_{OUT}}{0.925V} - 1 \right) \quad (1)$$

Table1—Recommended Resistance Values:

VOUT	R1	R2
1V	1.0KΩ	12KΩ
1.2V	3.0KΩ	10KΩ
1.8V	9.53KΩ	10KΩ
2.5V	16.9KΩ	10KΩ
3.3V	26.1KΩ	10KΩ
5V	44.2KΩ	10KΩ
12V	121KΩ	10KΩ

Inductor Selection

The inductor maintains a continuous current to the output load. This inductor current has a ripple that is dependent on the inductance value: higher inductance reduces the peak-to-peak ripple current. The trade off for high inductance value is the increase in inductor core size and series resistance, and the reduction in current handling capability. In general,

select an inductance value.

L based on the ripple current requirement:

$$L = \frac{V_{OUT} \cdot (V_{IN} - V_{OUT})}{V_{IN} f_{SW} I_{OUTMAX} K_{RIPPLE}} \quad (2)$$

Where VIN is the input voltage, VOUT is the output voltage, f_{SW} is the switching frequency, IOUTMAX is the maximum output current, and KRIPPLE is the ripple factor. Typically, choose KRIPPLE $\approx 30\%$ to correspond to the peak-to-peak ripple current being $\approx 30\%$ of the maximum output current.

With this inductor value, the peak inductor current is $I_{OUT} \cdot (1 + K_{RIPPLE}/2)$. Make sure that this peak inductor current is less than the upper switch current limit. Finally, select the inductor core size so that it does not saturate at the current limit. Typical inductor values for various output voltages are shown in Table 2.

Table 2. Typical Inductor Values

VOUT	1V	1.2V	1.8V	2.5V	3.3V	5V	9V
L	4.7uH	4.7uH	10uH	10uH	10uH	10uH	22uH

Input Capacitor

The input capacitor needs to be carefully selected to maintain sufficiently low ripple at the supply input of the converter. A low ESR Electrolytic (EC) capacitor is highly recommended. Since large current flows in and out of this capacitor during switching, its ESR also affects efficiency.

When EC cap is used, the input capacitance needs to be equal to or higher than 68uF. The RMS ripple current rating needs to be higher than 50% of the output current. The input capacitor should be placed close to the VIN and GND pins of the IC, with the shortest traces possible. The input capacitor can be placed a little bit away if a small parallel 0.1 uF ceramic capacitor is placed right next to the IC.

When Vin is >15V, pure ceramic Cin (* no EC cap) is not recommended. This is because the ESR of a ceramic cap is often too small, Pure ceramic Cin will work with the parasite

inductance of the input trace and forms a V_{in} resonant tank. When V_{in} is hot plug in/out, this resonant tank will boost the V_{in} spike to a very high voltage and damage the IC.

Output Capacitor

The output capacitor also needs to have low ESR to keep low output voltage ripple. In the case of ceramic output capacitors, R_{ESR} is very small and does not contribute to the ripple. Therefore, a lower capacitance value can be used for ceramic capacitors. In the case of tantalum or electrolytic capacitors, the ripple is dominated by R_{ESR} multiplied by the ripple current. In that case, the output capacitor is chosen to have sufficiently low ESR.

For ceramic output capacitors, typically choose of about 22uF. For tantalum or electrolytic capacitors, choose a capacitor with less than 50mΩ ESR.

Optional Schottky Diode

During the transition between high-side switch and low-side switch, the body diode of the low side power MOSFET conducts the inductor current. The forward voltage of this body diode is high. An optional Schottky diode may be paralleled between the SW pin and GND pin to improve overall efficiency.

Stability Compensation

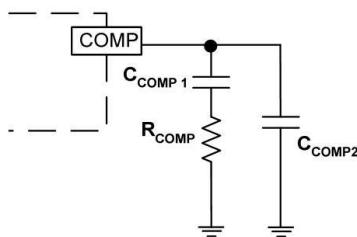

Figure 2. Stability Compensation

C_{COMP2} is needed only for high ESR output capacitor.

The feedback loop of the IC is stabilized by the components at the COMP pin, as shown in Figure

2. The DC loop gain of the system is determined by the following equation:

$$A_{VDC} = \frac{0.925 V}{I_{OUT}} A_{VEA} G_{COMP} \quad (4)$$

The dominant pole P1 is due to C_{COMP1} :

$$f_{P1} = \frac{G_{EA}}{2\pi A_{VEA} C_{COMP1}} \quad (5)$$

The second pole P2 is the output pole:

$$f_{P2} = \frac{I_{OUT}}{2\pi V_{OUT} C_{OUT}} \quad (6)$$

The first zero Z1 is due to R_{COMP} and C_{COMP1} :

$$f_{Z1} = \frac{1}{2\pi R_{COMP} C_{COMP1}} \quad (7)$$

And finally, the third pole is due to R_{COMP} and C_{COMP2} (if C_{COMP2} is used):

$$f_{P3} = \frac{1}{2\pi R_{COMP} C_{COMP2}} \quad (8)$$

The following steps should be used to compensate the IC:

STEP1. Set the crossover frequency at 1/10 of the switching frequency via R_{COMP} :

$$R_{COMP} = \frac{2\pi V_{OUT} C_{OUT} f_{SW}}{10 G_{EA} G_{COMP} \cdot 0.925 V} \quad (9)$$

but limit R_{COMP} to 10KΩ maximum. More than 10 KΩ is easy to cause overshoot at power on.

STEP2. Set the zero f_{Z1} at 1/4 of the crossover frequency. If R_{COMP} is less than 10KΩ, the equation for C_{COMP1} is:

$$C_{COMP1} = \frac{0.637}{R_{COMP} \times f_c} (F) \quad (10)$$



STEP3. If the output capacitor's ESR is high enough to cause a zero at lower than 4 times the crossover frequency, an additional compensation capacitor C_{COMP2} is required. The condition for using C_{COMP2} is:

$$\pi \times C_{OUT} \times R_{ESR} \times f_S \geq 1 \quad (11)$$

And the proper value for C_{COMP2} is:

$$C_{COMP2} = \frac{C_{OUT} R_{ESR} C_{OUT}}{R_{COMP}} \quad (12)$$

Though C_{COMP2} is unnecessary when the output capacitor has sufficiently low ESR, a small value C_{COMP2} such as 100pF may improve stability against PCB layout parasitic effects

Table 4 – Component Selection Guide for Stability Compensation

Vin Range (V)	Vout (V)	Cout	Rcomp (R3)(kΩ)	Ccomp (C4)(nF)	Ccomp2 (C5)(pF)	Inductor (uH)
5 – 12	1.0	22uFx2 Ceramic	3.3	5.6	none	4.7
5 – 15	1.2		3.9	4.7	none	4.7
5 – 15	1.8		5.6	3.3	none	10
5 – 15	2.5		8.2	2.2	none	10
5 – 15	3.3		10	2	none	10
5 – 15	5		10	3.3	none	10
5 – 12	1.0	470uF/ 6.3V/120mΩ	10	6.8	680	4.7
5 – 15	1.2					10
5 – 23	1.8					
5 – 27	2.5					
5 – 27	3.3					
5 – 27	5					



Outline Drawing For SOP8

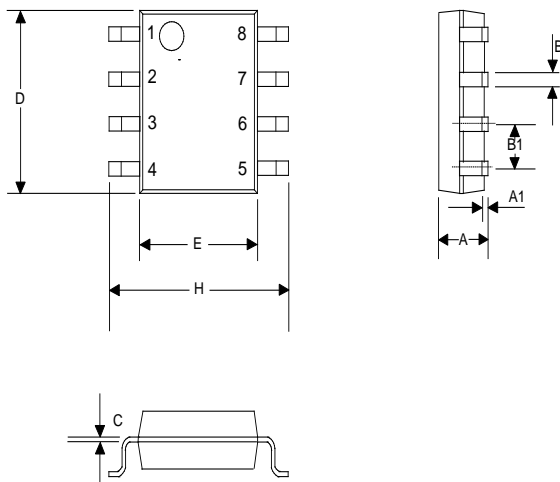

DIM	DIMENSIONS			
	INCHES		MM	
	MIN	MAX	MIN	MAX
A	0.053	0.068	1.35	1.75
A1	0.0040	0.0098	0.10	0.25
B	0.0130	0.0200	0.33	0.51
B1	0.050	BS	1.27	BS
C	0.0075	0.0098	0.19	0.25
D	0.1890	0.1968	4.80	5.00
H	0.2284	0.2440	5.80	6.20
E	0.1497	0.1574	3.80	4.00

Outline Drawing For PSOP8

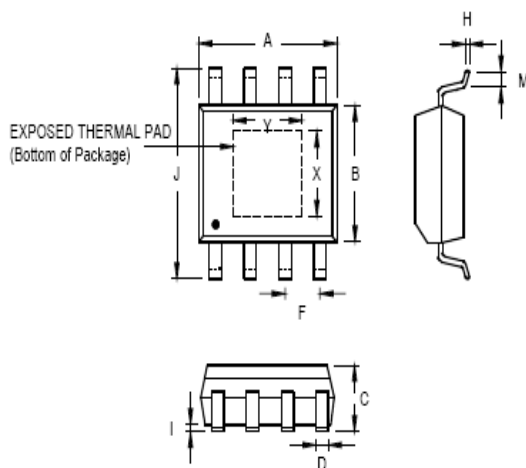

Symbol	Dimensions In Millimeters		Dimensions In Inches	
	Min	Max	Min	Max
A	4.801	5.004	0.189	0.197
B	3.810	3.988	0.150	0.157
C	1.346	1.753	0.053	0.069
D	0.330	0.508	0.013	0.020
F	1.194	1.346	0.047	0.053
H	0.191	0.254	0.008	0.010
I	0.000	0.152	0.000	0.006
J	5.791	6.198	0.228	0.244
M	0.406	1.270	0.016	0.050
X	2.057	2.515	0.081	0.099
Y	2.057	3.404	0.081	0.134



联系方式:

北京思旺电子有限公司-中国总部

地址: 中国北京市海淀区信息路 22 号上地科技综合楼 B 座二层

邮编: 100085

电话:010-82895700/1/5

传真:010-82895706

Seaward Electronics Corporation – 台湾办事处

2F, #181, Sec. 3, Minquan East Rd,

Taipei, Taiwan R.O.C

电话: 886-2-2712-0307

传真: 886-2-2712-0191

Seaward Electronics Incorporated – 北美办事处

1512 Centre Pointe Dr.

Milpitas, CA95035, USA

电话: 1-408-821-6600