



Description

SE3912 is a high performance offline PWM controller for low power AC/DC charger and adaptor applications. It operates in primary-side regulation. Consequently, opto-coupler and voltage reference IC such as SE431 could be eliminated. Proprietary Constant Voltage (CV) and Constant Current(CC) control are integrated.

In CC control, the current and output power setting can be adjusted externally by the sense resistor R_s at CS pin. In CV control, multi-mode operations are utilized to achieve high performance and high efficiency. In addition, good load regulation is achieved by the built-in wireless compensation.

SE3912 offers power-on soft-start control and protection coverage with auto-recovery features including Cycle-by Cycle current limiting, VCC UVLO,OTP, SCP. Excellent EMI performance is achieved with frequency shuffling technique.

SESE3912 is available in SOT23-6 packages.

Features

- High precision constant voltage(CV) and constant current (CC) output.
- Primary-Side- Regulation without secondary voltage reference and Opto-coupler.
- Programmable CV and CC Regulation.
- Built- in Adaptive Peak Current Regulation
- Programmable wireless Compensation
- Power-on Soft-Start.
- Flyback Topology in DCM Operation
- Built-in Leading Edge Blanking(LEB)
- Cycle-by-Cycle Current Limiting
- VCC under voltage lockout (UVLO).
- Short Circuit Protection.
- Over Temperature Protection.
- Available in SOT23-6 Packages.
- RoHS Compliant and 100% Lead (Pb)-Free

Applications

- Cell Phone Charger
- Small Power Adaptor
- Lower Power LED drivers
- Linear Regulator/RCC Replacement.

Pin Configuration

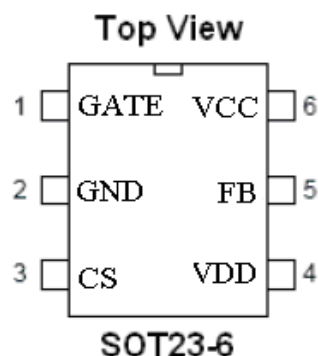



Pin Function

Pin Num	Pin Name	Description
1	GATE	This pin drives the base of external power NPN switch.
2	GND	Ground
3	CS	The primary current sense
4	VDD	The output of the internal voltage regulator.
5	FB	The voltage feedback from the auxiliary winding.
6	VCC	Supply voltage.

Application Diagram

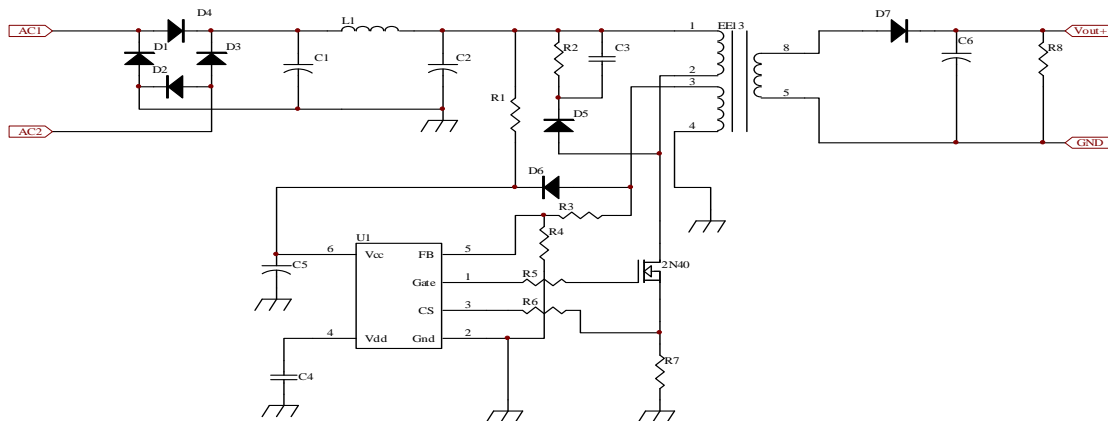



OUTLINE DRAWING SOT23_6

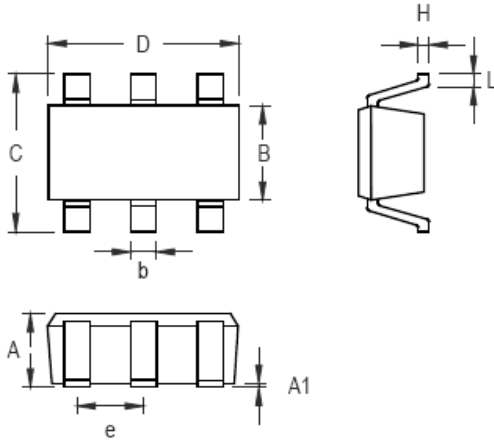

Symbol	Dimensions In Millimeters		Dimensions In Inches	
	Min	Max	Min	Max
A	0.889	1.295	0.031	0.051
A1	0.000	0.152	0.000	0.006
B	1.397	1.803	0.055	0.071
b	0.250	0.560	0.010	0.022
C	2.591	2.997	0.102	0.118
D	2.692	3.099	0.106	0.122
e	0.838	1.041	0.033	0.041
H	0.080	0.254	0.003	0.010
L	0.300	0.610	0.012	0.024

Customer Support

Seaward Electronics Incorporated – China

Section B, 2nd Floor, ShangDi Scientific Office Complex, #22 XinXi Road
Haidian District, Beijing 100085, China
Tel: 86-10-8289-5700/01/05
Fax: 86-10-8289-5706

Seaward Electronics Corporation – Taiwan

2F, #181, Sec. 3, Minguan East Rd,
Taipei, Taiwan R.O.C
Tel: 886-2-2712-0307
Fax: 886-2-2712-0191

Seaward Electronics Incorporated – North America

1512 Centre Pointe Dr.
Milpitas, CA95035, USA
Tel: 1-408-821-6600

Last Updated - 12/11/2010