



General Description

The SE9175 is a simple, cost-effective and high-speed linear regulator designed to generate termination voltage in double data rate (DDR) memory system to comply with the JEDEC SSTL_2 and SSTL_18 or other specific interfaces such as HSTL, SCSI-2 and SCSI-3 etc. devices requirements. The regulator is capable of actively sinking or sourcing up to 2A while regulating an output voltage to within 40mV. The output termination voltage can be tightly regulated to track $1/2V_{DDQ}$ by two external voltage divider resistors or the desired output voltage can be programmed by externally forcing the REFEN pin voltage.

The SE9175 also incorporates a high-speed differential amplifier to provide ultra-fast response in line/load transient. Other features include extremely low initial offset voltage, excellent load regulation, current limiting in bi-directions and on-chip thermal shut-down protection.

The SE9175 are available in the PSOP-8 (Exposed Pad) surface mount packages.

Features

- Ideal for DDR-I, DDR-II and DDR-III VTT Applications
- Sink and Source 2A Continuous Current
- Integrated Power MOSFETs
- Generates Termination Voltage for SSTL_2, SSTL_18, HSTL, SCSI-2 and SCSI-3 Interfaces.
- High Accuracy Output Voltage at Full-Load
- Output Voltage traces REFEN Pin Voltage.
- Low External Component Count
- Shutdown for Suspend to RAM (STR) Functionality with High-Impedance Output
- Current Limiting Protection
- Thermal Shutdown Protection
- PSOP-8 with exposed pad Pb-Free Package.

Applications

- Desktop PCs, Notebooks, and Workstations
- Graphics Card Memory Termination
- Set Top Boxes, Digital TVs, Printers
- Embedded Systems
- Active Termination Buses
- DDR-I, DDR-II and DDR-III Memory Systems



Typical Application

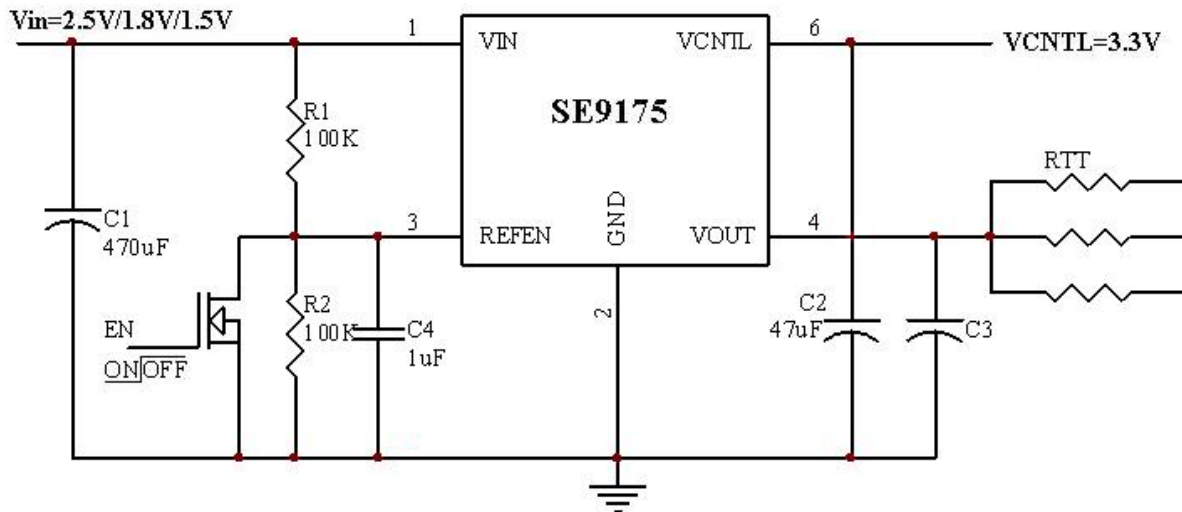

$R_{TT}=50\Omega /33\Omega /25\Omega$

$C_3=10\mu\text{F}$ (Ceramic) +1000 μF under the worst case testing condition

Pin Configuration

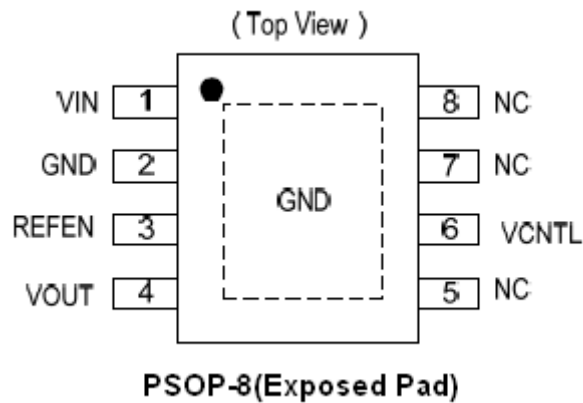

Pin Description

NO.	Pin Name	Pin Function Description
1	VIN	Input Voltage pin
2	GND	Ground pin
3	REFEN	Reference voltage input and chip enable pin
4	VOUT	Output Voltage pin
5,7,8	NC	No connect pin
6	VCNTL	Supply Input and Gate drive voltage pin



Functional Block Diagram

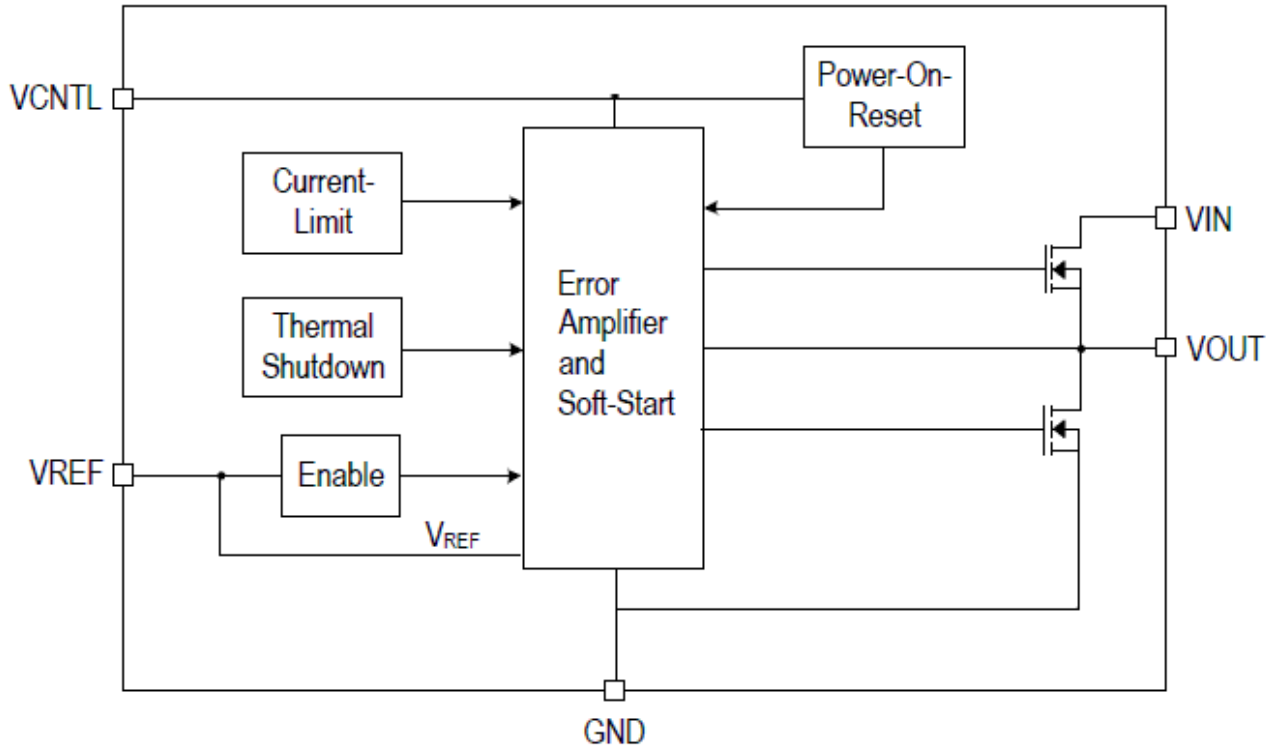

Ordering Information

Part Number	Marking Information	Package	Remarks
SE9175-XX	SE9175 YYWW-XX	PSOP-8	YYWW means Production batch XX=LF: Lead Free. XX=HF: Halogen Free.

Absolute Maximum Ratings

Symbol	Parameter	Maximum	Units
V_{IN}	V_{IN} Supply Voltage	6	V
V_{CNTL}	Control Voltage	6	V
PD	Power Dissipation	Internally Limited	W
T_{ST}	Storage Temperature Range	-40 to +150	°C
θ_{JC}	Thermal Resistance from Junction to case	15	°C/W
θ_{JA}	Thermal Resistance from Junction to ambient	40	°C/W

Note: θ_{JA} is measured with the PCB copper area (need connect to Exposed pad) of approximately 1.5^2



Recommended Operating Conditions

Symbol	Parameter	Maximum	Units
V_{IN}	Input Voltage	1.3 to V_{CNTL}	V
V_{CNTL}	Control Voltage	5 or 3.3	V
T_A	Ambient Temperature	-40 to +85	°C
T_J	Junction Temperature	-40 to +125	°C

Note: V_{OS} offset is the voltage measurement defined as V_{OUT} subtracted from V_{REFEN} .

Electrical Characteristics

($V_{IN}=2.5V/1.8V/1.5V$, $V_{CNTL}=3.3V$, $V_{REFEN}=1.25V/0.9V/0.75V$, $C_{OUT}=10\mu F$ (Ceramic),;

$T_J=25^\circ C$ unless otherwise specified)

Symbol	Parameter	Test Conditions	Min	Typ	Max	Unit
V_{CNTL}	Gate Drive Voltage Range		-	3.3	5.5	V
$V_{CNTLRTH}$	POR Threshold		-	2.55	-	V
V_{CNTL}	POR Hysteresis		-	0.1	-	V
V_{IN}	Input Voltage		1.3	-	V_{CNTL}	V
I_{CNTL}	Quiescent Current	$I_{OUT}=0A$	-	1	3	mA
I_{STBY}	Standby Current	$I_{OUT}=0A$, $V_{REFEN}=0V$	-	1	10	uA
V_{OS}	Output Offset Voltage (Note1)	$I_{OUT}=0A$	-20	-	+20	mV
ΔV_{LOAD}	Load Regulation (Note2)	$I_{OUT}=\pm 2.0A$	-	0.5	± 20	%
V_{IH}	Shutdown Threshold	Enable, REFEN Rising	0.65	-	-	V
V_{IL}		Shutdown, REFEN Falling	-	-	0.2	V
$I_{CL-Source}$	Current Limit	Sourcing	2.1	-	-	A
$I_{CL-Sink}$		Sinking	2.1	-	-	A
T_{SS}	Soft-Start Period	$V_{OUT}=1.25V$	-	1.4	-	ms
T_{SD}	Thermal Shutdown		-	155	-	°C
T_{SDH}	Thermal Shutdown Hysteresis		-	30	-	°C

Note 1: V_{OS} offset is the voltage measurement defined as V_{OUT} subtracted from V_{REFEN} .

Note 2: Regulation is measured at constant junction temperature by using a 5ms current pulse. Devices are tested for load regulation in the load range from 0A to 2A.



Typical Performance Characteristics

Transient Test

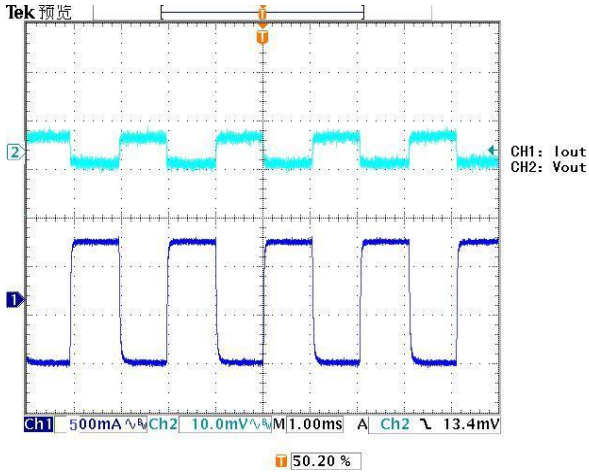

$V_{IN}=2.5V, V_{OUT}=1.25V, V_{CNL}=3.3V, I_{OUT}=1.5A$

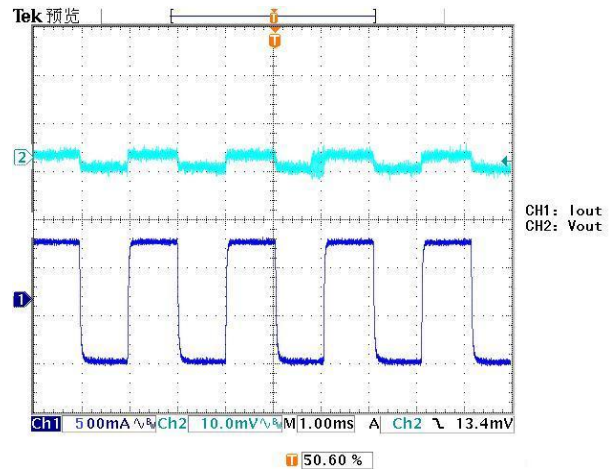

$V_{IN}=2.5V, V_{OUT}=1.25V, V_{CNL}=3.3V, I_{OUT}=-1.5A$

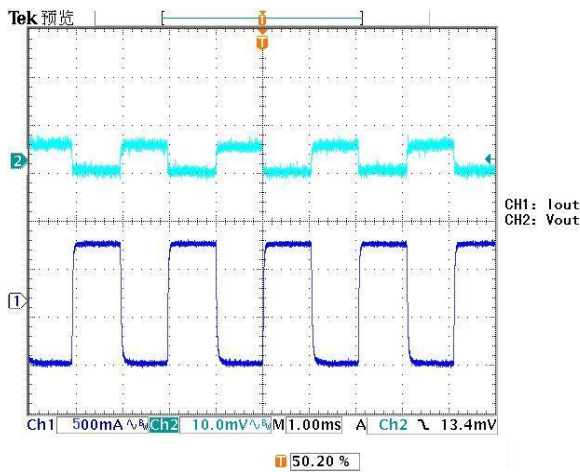

$V_{IN}=1.8V, V_{OUT}=0.9V, V_{CNL}=3.3V, I_{OUT}=1.5A$

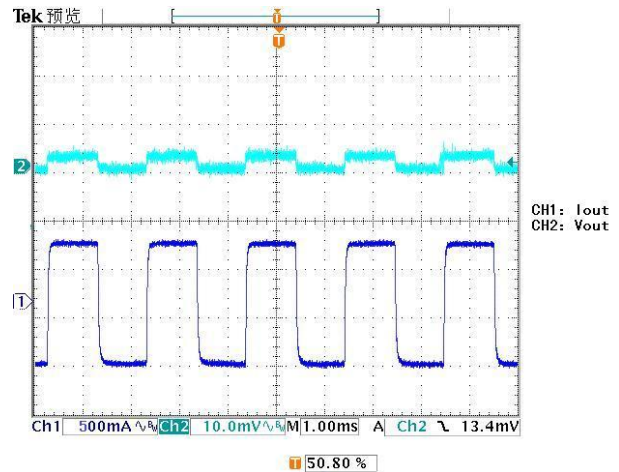

$V_{IN}=1.8V, V_{OUT}=0.9V, V_{CNL}=3.3V, I_{OUT}=-1.5A$

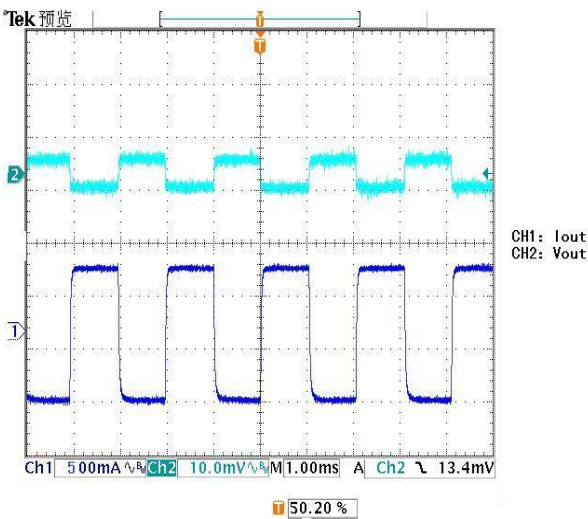

$V_{IN}=1.5V, V_{OUT}=0.75V, V_{CNL}=3.3V, I_{OUT}=1.5A$

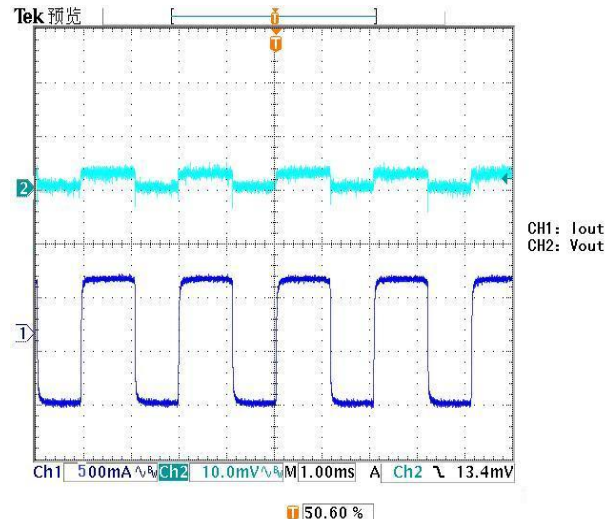

$V_{IN}=1.5V, V_{OUT}=0.75V, V_{CNL}=3.3V, I_{OUT}=-1.5A$



Typical Performance Characteristics (continuous)

Soft-Start

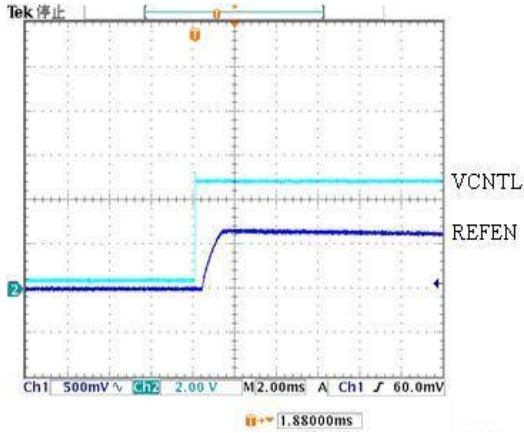

$V_{in}=1.5V, V_{OUT}=0.75V,$
 $I_{OUT}=0mA, V_{CNL}(3.3V)$ Power-on

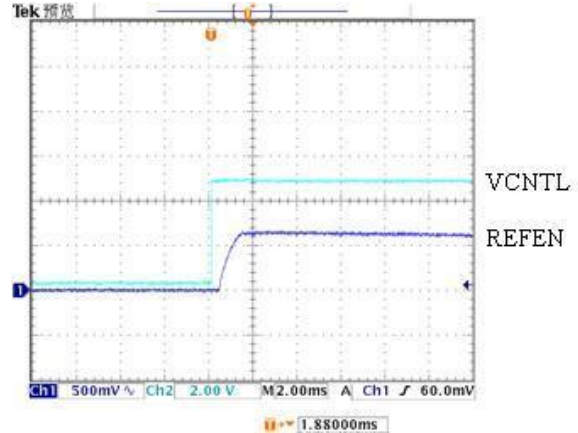

$V_{in}=1.5V, V_{OUT}=0.75V,$
 $I_{OUT}=1A, V_{CNL}(3.3V)$ Power-on

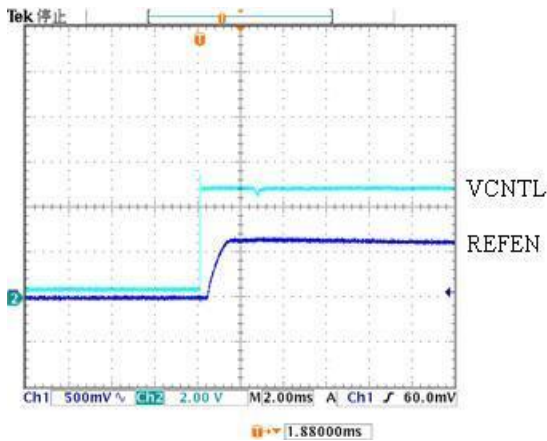

$V_{in}=1.5V, V_{OUT}=0.75V,$
 $I_{OUT}=2A, V_{CNL}(3.3V)$ Power-on

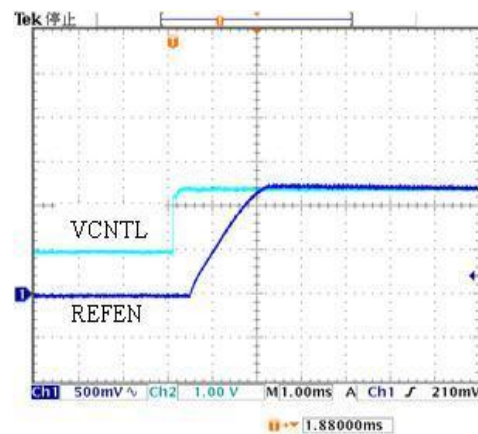

$V_{in}(1.5V)$ Power-on, $V_{OUT}=0.75V,$
 $I_{OUT}=0mA, V_{CNL}=3.3V$

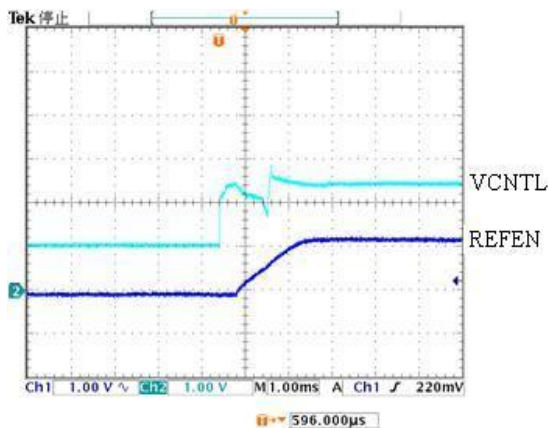

$V_{in}(1.5V)$ Power-on, $V_{OUT}=0.75V,$
 $I_{OUT}=1A, V_{CNL}=3.3V$

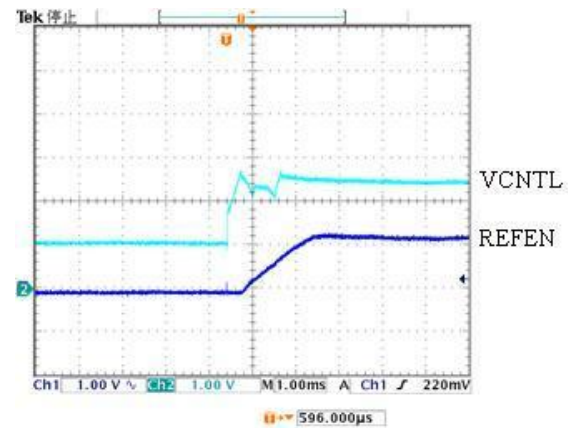

$V_{in}(1.5V)$ Power-on, $V_{OUT}=0.75V,$
 $I_{OUT}=2A, V_{CNL}=3.3V$



Typical Performance Characteristics (continuous)

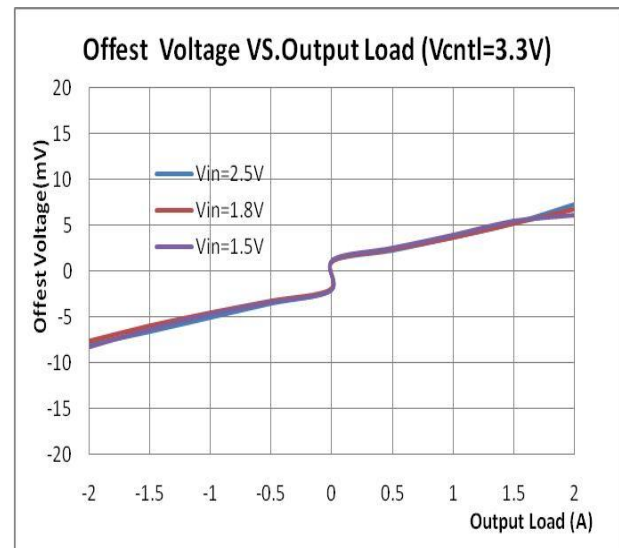
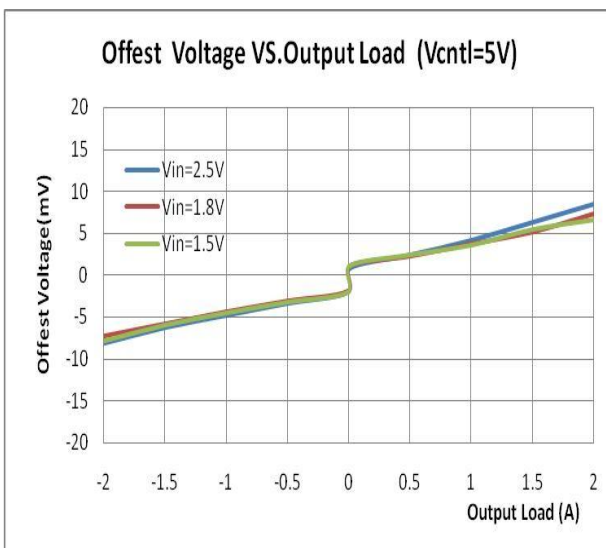
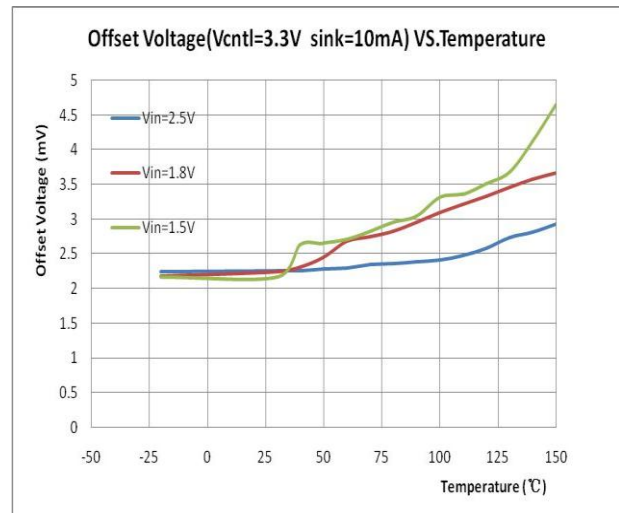
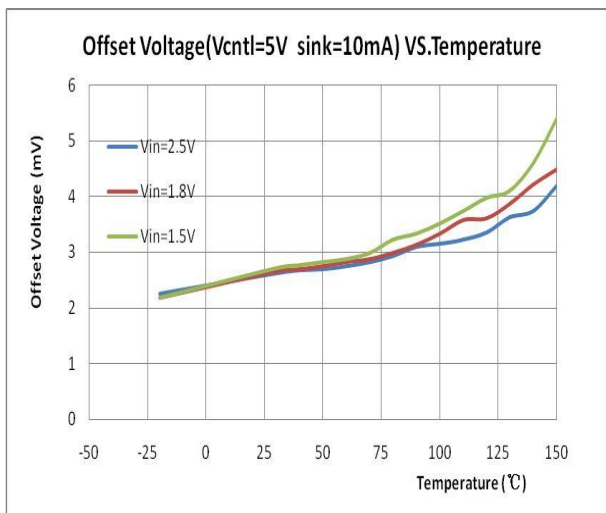
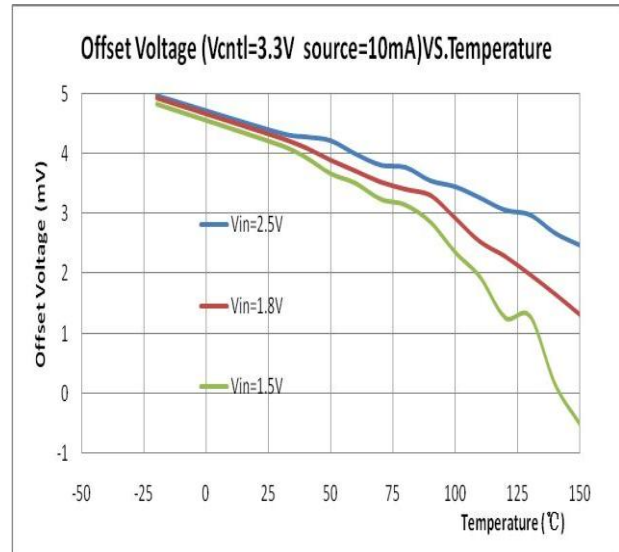
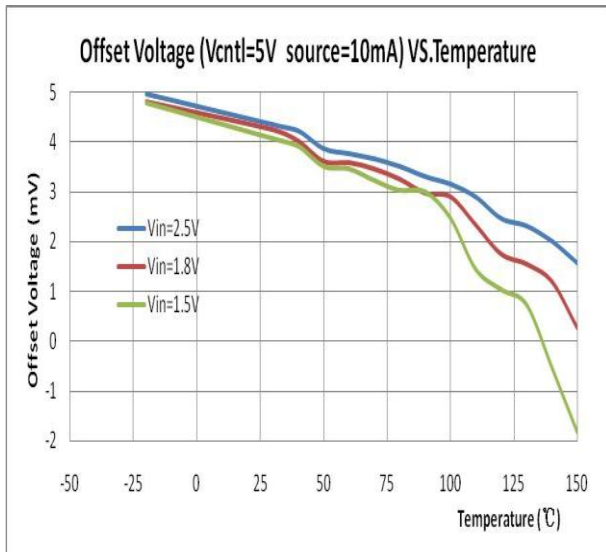



Applications Information

Input Capacitor and Layout Consideration

Place the input bypass capacitor as close as possible to the SE9175. A low ESR capacitor larger than 470uF is recommended for the input capacitor. Use short and wide traces to minimize parasitic resistance and inductance. Inappropriate layout may result in large parasitic inductance and cause undesired oscillation between SE9175 and the preceding power converter.

Consideration while designs the resistance of voltage divider

Make sure the sinking current capability of pull-down NMOS if the lower resistance was chosen so that the voltage on V_{REFEN} is below 0.2V. In addition, the capacitor and voltage divider form the low pass filter. There are two reasons doing this design; one is for output voltage soft-start while another is for noise immunity.

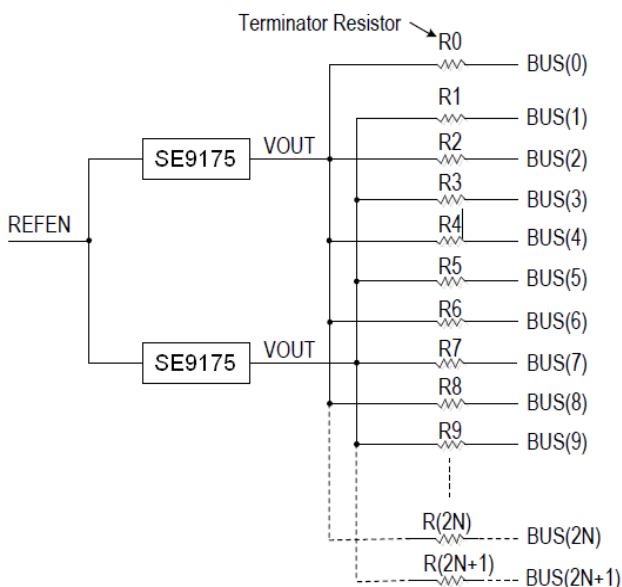

Thermal Considerations

The SE9175 series can deliver a current of up to 2A over the full operating junction temperature range.

However, the maximum output current must be dated at higher ambient temperature to ensure the junction temperature does not exceed 125°C. With all possible conditions, the junction temperature must be within the range specified under operating conditions. Power dissipation can be calculated based on the output current and the voltage drop across regulator.

$$P_D = (V_{IN} - V_{OUT}) \times I_{OUT} + V_{IN} \times I_Q$$

The final operating junction temperature for any set of conditions can be estimated by the following thermal equation:

$$P_{D(MAX)} = (T_{J(MAX)} - T_A) / \theta_{JA}$$

Where $T_{J(MAX)}$ is the maximum junction temperature of the die (125°C) and T_A is the maximum ambient temperature. The junction to ambient thermal resistance (θ_{JA}) for PSOP-8L-EP (Exposed pad) package at recommended minimum footprint is 40°C/W on 1.5² and Multi-layer PCB layout. The maximum power dissipation at $T_A = 25^\circ\text{C}$ can be calculated by following formula:

$$P_{D(MAX)} = (125^\circ\text{C} - 25^\circ\text{C}) / 40^\circ\text{C/W} = 2.5\text{W}$$

The thermal resistance θ_{JA} of PSOP-8 (Exposed Pad) is determined by the package design and the PCB design. However, the package design has been decided. If possible, it's useful to increase thermal performance by the PCB design. The thermal resistance can be decreased by adding copper under the expose pad of PSOP-8L-EP package. We have to consider the copper couldn't stretch infinitely and avoid the tin overflow.



Outline Drawing For PSOP-8L-EP

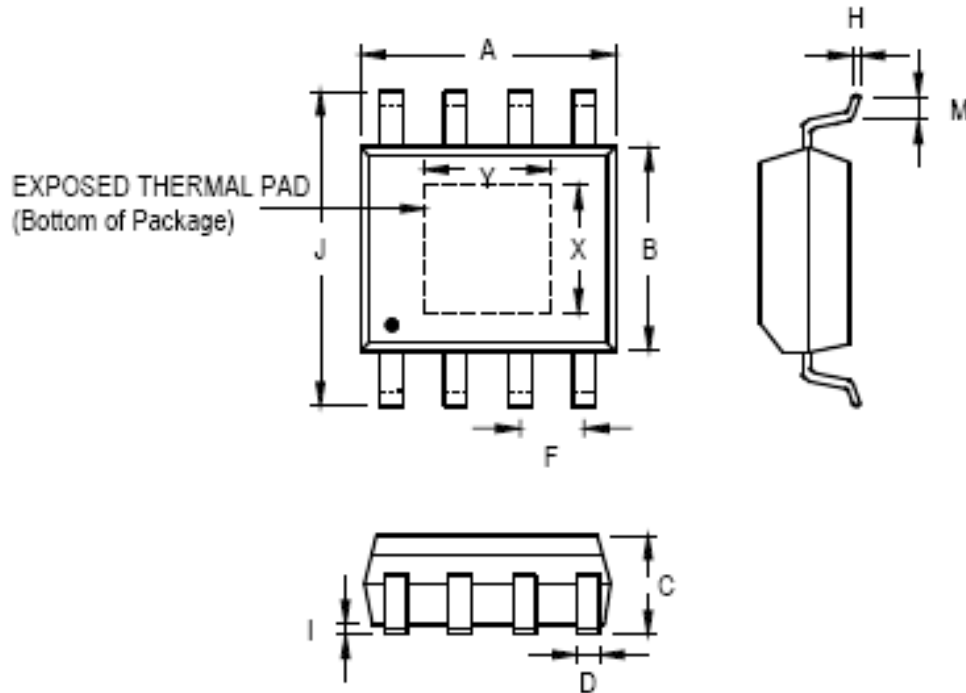

Symbol	Dimensions In Millimeters		Dimensions In Inches	
	Min	Max	Min	Max
A	4.801	5.004	0.189	0.197
B	3.810	3.988	0.150	0.157
C	1.346	1.753	0.053	0.069
D	0.330	0.508	0.013	0.020
F	1.194	1.346	0.047	0.053
H	0.191	0.254	0.008	0.010
I	0.000	0.152	0.000	0.006
J	5.791	6.198	0.228	0.244
M	0.406	1.270	0.016	0.050
X	2.057	2.515	0.081	0.099
Y	2.057	3.404	0.081	0.134



联系方式:

北京思旺电子有限公司-中国总部

地址: 中国北京市海淀区信息路 22 号上地科技综合楼 B 座二层

邮编: 100085

电话:010-82895700/1/5

传真:010-82895706

Seaward Electronics Corporation – 台湾办事处

2F, #181, Sec. 3, Minguan East Rd,

Taipei, Taiwan R.O.C

电话: 886-2-2712-0307

传真: 886-2-2712-0191

Seaward Electronics Incorporated – 北美办事处

1512 Centre Pointe Dr.

Milpitas, CA95035, USA

电话: 1-408-821-6600